

CONVERSION OF INTERNAL COMBUSTION ENGINE TO COMPRESSED AIR SUPPLY WITH APPLICATION OF SOLENOID VALVE IN CYLINDER FILLING SYSTEM

Michał Korbut, Michał Kuszniar, Dariusz Szpica

Białystok University of Technology, Poland

korbutmichal@gmail.com, m.kuszniar@doktoranci.pb.edu.pl, d.szpica@pb.edu.pl

Abstract. The increasing public awareness of the negative impact of harmful substances emitted as a result of the operation of vehicles powered by internal combustion engine on health and the environment has contributed to the dynamic development and popularization of alternative propulsion systems. The main development trend are electric drives; however, some manufacturers are looking for new solutions, among which the pneumatic drives can be distinguished. One of the advantages of this type of propulsion is the possibility of adapting currently used combustion engines to compressed air supply. The paper concentrates on presenting solutions applied by researchers to propulsion conversion, on the basis of which own concept is proposed. The modification process of a single-cylinder two-stroke engine for compressed air supply was described. The adaptation of the solenoid valve parameters as an actuator of the cylinder filling system was performed. This type of design allows for the start of the cylinder filling with compressed air at any time in relation to the crankshaft rotation angle. A functional diagram of the control process operation of the engine power system was developed which enables its correct operation. An important element of the system, in terms of the optimization of engine operation, was the opportunity to have an impact on selected power supply parameters. The purpose of this paper is to demonstrate the potential of utilizing existing components of an internal combustion engine to build a power unit, which does not require a combustion process to generate torque. The presented method of propulsion system conversion will allow for the popularization of compressed air supply system as an alternative propulsion source.

Keywords: mechanical engineering, pneumatic engine, solenoid valve.

Introduction

Conventional internal combustion engines as a stand-alone propulsion source are slowly being displaced from the market due to increasingly higher CO₂ emission standards imposed on vehicle manufacturers [1]. One of the alternative supply systems is the use of compressed air. This solution, invented in the 19th century, has frequently returned as an alternative for other sources of propulsion [2; 3]. Despite the many advantages of compressed air drives, limited emphasis is being put on their development. With regard to electric drives, which are currently the most popular alternative source of propulsion [4], they do not require the use of expensive and still not ecologically friendly in production batteries [5]. The great advantage is the possibility of using existing internal combustion engines and their components for converting power supply [6], thus the carbon footprint left by the drive is reduced already at the manufacturing stage. This is also contributing to the greatest popularity of solutions using reciprocating engines [7], although other proposals of unconventional solutions can also be found, including the following: scroll engine [8; 9], rotary engine [10], vane engine [11]. A disadvantage of pneumatic drives is the problem caused by the low energy density of the compressed air [12]. As a consequence, it is complicated to provide enough space in the vehicle for compressed air tanks of sufficient capacity to ensure an adequate operating range. An important element in the design of an air engine is the proper selection of the air dosing element to allow for the correct time and moment of supply. This could reduce compressed air consumption, which will contribute to improved performance. There are various types of air dosing elements, including mechanical solutions [13], or solutions using solenoid valves.

Conversion of the internal combustion engine to compressed air supply

In the literature many studies can be found on the conversion of the internal combustion engine to the compressed air supply [14-16]. Due to the fewer range of modifications, a two-stroke engine is usually used as the base of the propulsion unit. The most important stage of modification is the ensuring of appropriate dosage of compressed air in order to achieve efficient operating parameters. In the internal combustion engine, the timing system is responsible for the delivery of the charge to the cylinder. Over the years, a variety of solutions have been developed to enable, among other things for variable valve timing [17] or valve lift variation [18], in order to obtain the most efficient performance with sufficient economy. Those systems are designed to operate on four-stroke engines, what does not favour them to

be converted to compressed air power. In two-stroke engines, the timing is commonly realized through the exposing of the appropriate channels in the cylinder when the piston moves. The advantage of this solution is that there is no necessity to use separate engine timing components. The disadvantages are the symmetry of the timing system and the lack of ability to affect on the timing of the opening or closing of the channels in the engine. It is especially undesirable in the case of conversion to other fuel supply sources, due to the necessity for changes in valve timing relative to the fuel supply [19]. In addition, in most of the two-stroke engines, the load in the form of fuel mixed with oil and air is drawn into the crankcase, from where it reaches the cylinder through the scavenge channels. In this way, lubrication of the engine is also realised. This system is not suitable with a compressed air supply. A solution is the relocation of the compressed air intake from the intake channel to the engine head allowing it to enter directly above the piston. In the cylinder heads of spark-ignition internal combustion engines there is a space for the spark plug, which is unnecessary in the case of power conversion. This location is well suited for the placement of the compressed air inlet. In addition to the air dosing element for the engine 4, the pneumatic system consists of components, such as 1 compressed air tank, 2 air filter, 3 pressure regulator, 5 expanded air outlet.

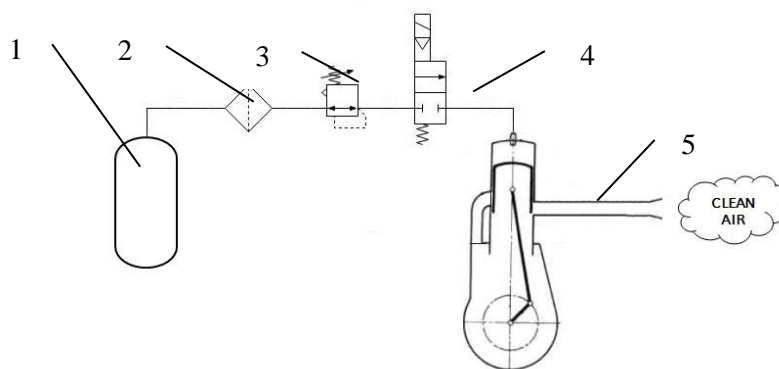

Fig. 1. Pneumatic system scheme of an engine supplied by compressed air

Compressed air dosing element solutions

Researchers in studies present various methods of compressed air supply. One of the simplest solutions is to use a mechanically opened valve. An example of such a solution is presented in [20]. The valve consists of a ball pressed by the air pressure and a spring into a seat in the cylinder head Fig. 2. The ball is placed in a perforated tube, which is its guiding element. A pin is mounted on the piston, which has the task of lifting the ball, causing the valve to open. As the piston moves downward, the valve automatically closes itself. The problem with the design is that the valve begins to open even before the piston reaches TDC (Top Dead Centre). The compressed air supply to the engine then creates resistance to the piston approaching TDC, resulting in a decrease in external engine performance.

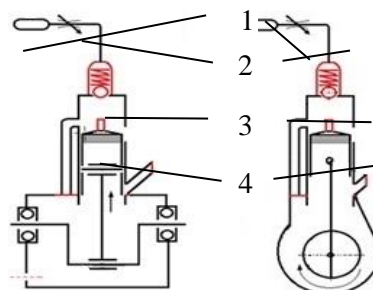

Fig. 2. Scheme of compressed air engine with mechanical valve:
1 – tank; 2 – valve; 3 – dosing valve; 4 – piston with rod [18]

In paper [21], the authors used a pneumatic valve as the compressed air dosing element with mechanical control using a roller lever (Fig. 3) built with 1 main valve, 2 pilot valve, 3 servo piston, 4 roller lever. In this case the valve remains normally closed and opens when pressure is applied to the

roller lever. The load is applied by a ring with a suitable cam, attached to the output of the engine crankshaft. The timing of opening and closing of the pneumatic valve in relation to the crankshaft rotation angle is determined by the shape of the cam pressing on the valve. The opening of the outlet canal is realized through a port in the cylinder exposed by the piston. In order to work as precisely as possible, the valve should be as close to the cam as possible, which results in it being located at a certain distance from the cylinder head. This can lead to a delay in valve operation due to the time required for the air to enter the inlet port in the cylinder head, which must be taken into account when setting the valve timing. In addition, at higher rotational speeds the valve can have problems with the correct opening time, which causes the supply air to become a resistance to the moving piston. The authors were able to achieve stable operation for rotational speed of $600 \text{ r} \cdot \text{min}^{-1}$.

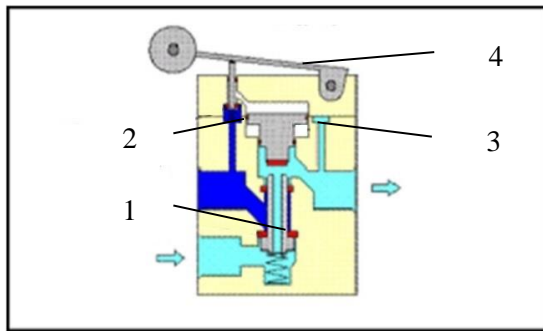

Fig. 3. Pneumatic valve with lever [19]

Fig. 4. Valve mounted on engine [19]

Another solution is to use a pneumatic solenoid valve. The operation of this valve can be controlled only electronically, which gives a wide range of configuration possibilities for the timing of valve opening and closing. Another advantage is the valve opening time - it has a delay caused by the valve opening process, however, it is shorter than in the mechanical valve. A similar solution has been applied in prototype internal combustion engines to control valve operation [22; 23]. The capability of high-precision controlling of the combustion process contributes to its improvement, which improves performance and lowers the emission of exhaust gases. Despite this, this solution has never been implemented mainly due to the reliability of the system. However, in case of pneumatic prototype engines, a more important factor than reliability is the possibility of wide range of adjustment the parameters of the power unit. For example, the opening of the solenoid valve can be performed by a magnetic connector controlled by a magnet [6] attached to the flywheel or by a dedicated controller. In the first case, the solution does not allow to differentiate valve opening and closing parameters according to, for example, engine rotational speed. As a result, efficient performance is achieved only at a certain range of rotational speeds. This may also lead to problems with stable operation at different rotational speeds, similar to the concept with a lever valve. The advantage is lower cost of the system and low complexity.

Object of the analysis

As the base for supply conversion, a single-cylinder two-stroke engine of 50 cm^3 capacity from a moped was used [24], Fig. 5. Due to the research character of the conversion, it was decided to use a solenoid valve 2 for dosing compressed air situated in the place after the spark plug. Standard pneumatic solenoid valves usually have inch threads; therefore, it was necessary to modify the threads in the engine head to enable installation of elements with the use of reduction adapter. It was also necessary to remove some of the motor cooling ribs in order to place the valve as close to the cylinder head as possible. When powered by compressed air, there is no combustion process generating heat, so this will not have a negative impact on the engine temperature. Furthermore, in the engine the serial elements of the supply system have been removed, and the intake canal 1 together with the flushing canals 3 have been blinded. The lack of fuel-oil mixture supply causes a problem with engine lubrication. It was decided to use lubrication from the gearbox, by making suitable holes to allow oil to pass between these components. The compressed air engine is not exposed to thermal stress, which contributes towards not having to ensure a very efficient lubrication system. Numerical studies [19] have shown that it is desirable to modify the compression ratio of the engine. The original compression ratio is 9.2:1 [24], which can

result in a higher pressure at the end of compression than the assumed supply pressure of 8 bar. This will have a negative impact on the proper running of the engine. For this purpose, shims were used between the cylinder and the cylinder head of engine 4 to change the compression ratio.

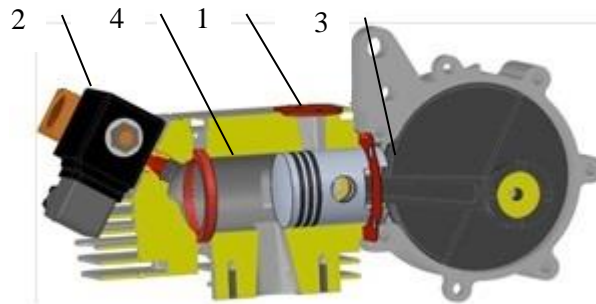

Fig. 5. Engine supply conversion [17]

Selected compressed air dosing element

In this study, it was decided to use a pneumatic solenoid valve 2M15 with an operating range up to a pressure of 16 bar, Fig. 6. This valve is normally closed, and 12V DC is required for its activation. In the closed position, a plunger 1 with a membrane 2 rests on a seat in the housing 4. The plunger is positioned in a guide pipe 3, mounted in the housing 4, sealed by an O-ring 5. A set of two springs 6 makes the valve in the closed position and the membrane rests on an inlet nozzle in the housing. Solenoid 9 is mounted on guide of the plunger 3 and secured by the washer 7 and the nut 8. When energizing the solenoid, the plunger 1 together with the membrane 2 rises allowing the air flow. When fully opened, the valve has a flow diameter of 4.5mm. This value has been verified by numerical calculations and should be sufficient to achieve an adequate flow rate.

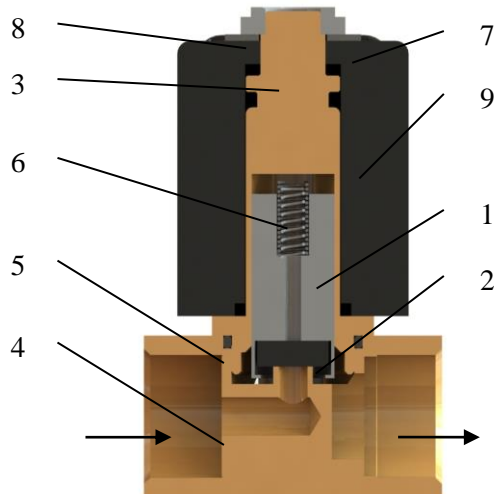

Fig. 6. Cross-section of the used solenoid valve (description in the main text)

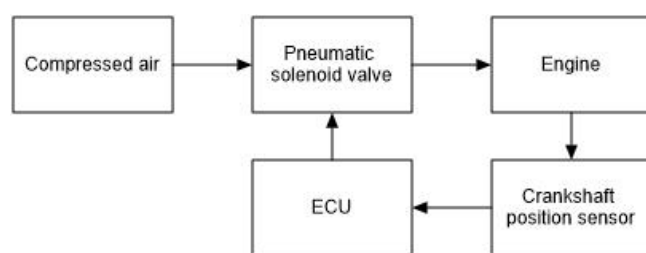

Fig. 7. Operating diagram of the solenoid valve control system

The used pneumatic solenoid valve delivers air directly to the cylinder chamber by 12V activation signal. Opening time of the valve is controlled by information from the encoder relating to the position of the crankshaft and engine speed. The time range for valve opening depends on the valve operating setting that can be adjusted by the controller. In order to accurately determine the appropriate timing of the signal for valve opening, the valve response time from the actuation should be determined, as well as the opening and closing times, as presented in the works [25; 26] in order to increase the precision of the dosed air and the timing of its delivery to the cylinder chamber.

The described engine in the course of calculations with the use of a simplified mathematical model consisted of a mechanical part, describing relations resulting from the mechanics of the crank-piston

system, and a pneumatic part, determining the change of pressure acting on the piston [27], achieving the parameters as follows: the power $P_1 = 0.78$ kW at speed $n_{p1} = 2460$ r·min⁻¹ and the torque $T_1 = 3.71$ Nm at speed $n_{T1} = 1413$ r·min⁻¹, respectively. These results can be compared to the performance of a mechanical valve engine [21]. Both engines have a similar design, their displacement is similar, being 50 cm³ and 60 cm³ accordingly. In the second case, the engine was able to operate at a maximum speed of 600 r·min⁻¹ achieving a power output of $P_2 = 0.17$ kW, and $T_2 = 1.87$ Nm. The variation among other things is due to the greater controllability of the valve opening parameters. In both cases, the achieved engine speed is lower than in the stock internal combustion engines. This is due to insufficient valve opening time at higher speeds, mainly due to the delay in operation.

Conclusions

The paper focuses on the issues of converting an internal combustion engine to compressed air supply. It has been decided to choose a pneumatic solenoid valve as the compressed air dosing element. The power unit is controlled by a dedicated controller. This design, after conducting experimental tests and adjusting operating parameters, can be used as a kit for modifying a specific internal combustion engine to run on compressed air. The next stage of work is to develop a testing station that allows to optimize the operation of the drive unit and to compare the results obtained by numerical methods. An expansion of the design is to use the solenoid valve to control the exhaust valve as well. This would allow for an even greater range of control of the air motor's operating parameters.

Funding

This publication was financed through the program of the Ministry of Science and Higher Education of Poland named "Regional Initiative of Excellence" in 2019-2022 project number 011/RID/2018/19.

Acknowledgements

This research was founded through the subsidy of the Ministry of Science and Higher Education of Poland for the discipline of mechanical engineering at the Faculty of Mechanical Engineering, Bialystok University of Technology WZ/WM-IIM/4/2020.

References

- [1] Clairotte M., Suarez-Bertoa R., Zardini A., Giechaskiel B., Pavlovic J., Valverde V., Ciuffo B., Astorga C. Exhaust emission factors of greenhouse gases (GHGs) from European road vehicles. *Environmental Sciences Europe*, vol. 32 (125), 2020, pp. 1-20.
- [2] Marvania D., Subudhi S. A comprehensive review on compressed air powered engine. *Renewable and Sustainable Energy Reviews*, vol. 70, 2017, pp. 1119-1130.
- [3] Wasbari F., Bakar R., Gan L., Tahir M., Yusof A. A review of compressed-air hybrid technology in vehicle system. *Renewable and Sustainable Energy Reviews*, vol. 67, 2017, pp. 935-953.
- [4] Hannan M., Azidin F., Mohamed A. Hybrid electric vehicles and their challenges: A review. *Renewable and Sustainable Energy Reviews*, vol. 29, 2014, pp. 135-150.
- [5] Onat N., Kucukvar M., Tatari O. Conventional, hybrid, plug-in hybrid or electric vehicles? State-based comparative carbon and energy footprint analysis in the United States. *Applied Energy*, vol. 150, 2015, pp. 36-49.
- [6] Kumar V., Takkar J., Chitransh M., Kumar N., Banka U., Gupta U. Development of an advanced compressed air engine kit for small engine. *SAE Technical Papers*, vol. 1, 2014, pp. 1-11.
- [7] Wang Y., You J., Sung C. The Applications of Piston Type Compressed Air Engines on Motor Vehicles. *Procedia Engineering*, vol. 79, 2014, pp. 61-65.
- [8] Ivlev V. I., Misyurin S. Yu. Calculated and experimental characteristics of a scroll machine operating in the air motor mode. *Doklady Physics*, vol. 62 (1), pp. 42-45.
- [9] Sergaliyev A., Khajiyeva L. Experimental Research and Mathematical Modeling of Scroll Machine in Air Motor Mode. *Advances in Mechanism Design II*, vol. 44, pp. 231-237.
- [10] Dvorak L., Fojtasek K., Rehacek V. Calculations of parameters and mathematical model of rotary air motor. *EPJ Web of Conferences*, vol. 143, 2017, pp. 1-4.
- [11] Badr O., Probert S.D., O'Callaghan P.W. Multi-vane expanders: internal-leakage losses. *Applied Energy*, vol. 20 (1), 1985, pp. 1-46.

- [12] Creutzig F., Papson A., Schipper L., Kammen, D. Economic and environmental evaluation of compressed-air cars. *Environmental Research Letters*, vol. 4, 2009, pp. 1-9.
- [13] Zwierzchowski J. Design type air engine Di Pietro. *EPJ Web of Conferences*, vol. 143, 2017, pp. 1-6.
- [14] Allam S., Zakaria M. Experimental Investigation of Compressed Air engine Performance. *International Journal of Engineering Inventions*, vol. 7, 2018, pp. 13-20.
- [15] Wang Y., You J., Sung C., Huang C. The applications of piston type compressed air engines on motor vehicles. *Procedia Engineering*, vol. 79, 2014, pp. 61-65.
- [16] Nabil T. Investigation and implementation of compressed air powered motorbike engines. *Engineering Reports*, vol. 1, 2019, pp. 1-13.
- [17] Fontana G., Galloni E. Variable valve timing for fuel economy improvement in a small spark-ignition engine. *Applied Energy*, vol. 86 (1), 2009, pp. 96-105.
- [18] Lou Z., Zhu G. Review of advancement in variable valve actuation of internal combustion engines. *Applied Sciences*, vol. 10, 2020, pp. 1-20.
- [19] Szpica D., Korbut M. Model assessment of inlet timing system impact on cylinder indicated pressure course of piston pneumatic engine. *Engineering for Rural Development: 19th International Scientific Conference*, 2020, pp. 711-720.
- [20] Kamiński M., Korbut M., Szpica D. Piston Pneumatic Engine - Preliminary Research. *Transport Means 2020 - Sustainability: Research and Solutions: Proceedings of the 24th International Scientific Conference P 1*. 2020, pp. 126-131.
- [21] Radhakrishna L., Gopikrishna N. Prefabricating and testing of air driven engine. *International Journal of Mechanical Engineering and Technology*, vol. 8 (11), 2017, pp. 238-251.
- [22] Kamlesh V., Pranay D. A Review on Camless Engine. *IJSRD - International Journal for Scientific Research & Development*, vol. 6 (1), 2018, pp. 147-150.
- [23] Nam K., Cho K., Park S., Choi S. Design and performance evaluation of an electro-hydraulic camless engine valve actuator for future vehicle applications. *Sensors*, vol. 17 (12), 2017, pp. 1- 14.
- [24] Jawa 50 technical data [online] [02.02.2021]. Available at: <http://www.jawa-50.cz/clanek/jawa-23-mustang-technicke-udaje.html>.
- [25] Szpica D., Kuszniar M. Model Evaluation of the Influence of the Plunger Stroke on Functional Parameters of the Low-Pressure Pulse Gas Solenoid Injector. *Sensors*, Vol. 21 (1) 234, 2021, pp. 1-17.
- [26] Szpica D., Kuszniar M. Modelling of the Low-Pressure Gas Injector Operation. *Acta Mechanica et Automatica* vol. 14 (1), 2020, pp. 29-35.
- [27] Szpica D., Korbut M. Modelling Methodology of Piston Pneumatic Air Engine Operation. *Acta Mechanica et Automatica* vol. 13 (4), 2019, pp. 271-278.